

Patriot



K12 certified electro-hydraulic rising beam

Boon Edam's Patriot beams offer the highest level of protection for your access points. Minimal excavation is required across the roadway. The Patriot is K12 crash test certified by the US Department Of State and has proven to stop a 6800kg vehicle travelling against 80km/h.

The Patriot rising beam has a full guard height of 914mm. Installed in-ground, the unit requires a maximum excavation of 1676mm on the outside areas of the roadway, avoiding excavation where

most underground utilities and obstructions reside. The Patriot allows paved stones on the roadway directly adjacent to the barrier and is flush to the roadway when open.

Your **Security.** Our **Solution.**

Construction

- The Patriot is K12 certified by the U.S. Department Of State (DOS).
- All steel parts are standard hot dipped galvanised for corrosion protection.
- Highly visible yellow stripes are standard. Custom specified paint colors are available.
- Construction and installation by others, such as concrete foundation, rebar, roadway surface, conduit, wiring and hydraulic hoses.

Features & Options

<i>Characteristics</i>	<i>Std</i>	<i>Opt</i>
Manual hand pump	•	
Hot-dipped galvanised	•	
Standard main operator control panel	•	
Custom main operator control panel		•
Remote operator control panel		•
2.2kW hydraulic unit	•	
3.7kW hydraulic unit		•
7.5kW hydraulic unit		•
Barrier-up position sensor	•	
Barrier-down position sensor	•	
Hydraulic oil heater/cooler		•
Emergency Fast Operate (EFO)	•	
Vehicle detection loops		•
Traffic signal lights		•
Weather proof HPU enclosure	•	
Custom painted finish		•
PLC Programming	•	
Battery backup		•
Electrical Power Voltages:		
208-240 Volt AC, 3-Phase, 60 Hertz	•	
115-120 Volt AC, Single-Phase		•
208-240 Volt AC, Single Phase		•
380 Volt AC, 3-Phase		•
440-480 Volt AC, 3-Phase		•

Dimensions (mm)

<i>A</i>	<i>B</i>	<i>C</i>	<i>D</i>	<i>E*</i>	<i>F</i>	<i>G</i>	<i>H</i>	<i>J</i>	<i>K</i>
5131	2134	1676	914	3658	622	1524	1067	305	2194
8788	2134	1676	914	7315	622	1524	1067	305	2194

* Widths can range between 3.6m and 7.3m

FRONT VIEW

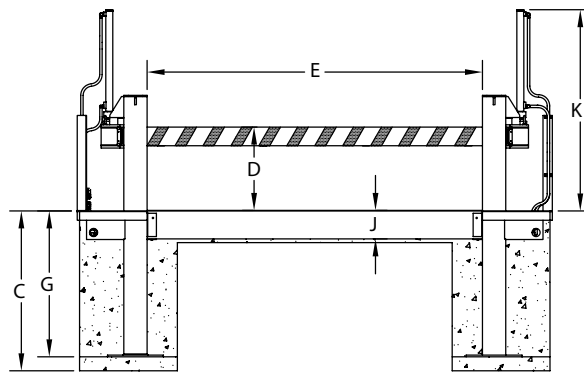

TOP VIEW

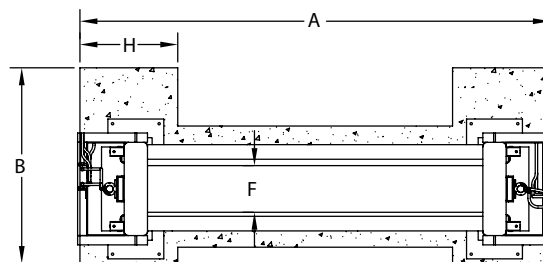

ISOMETRIC VIEW

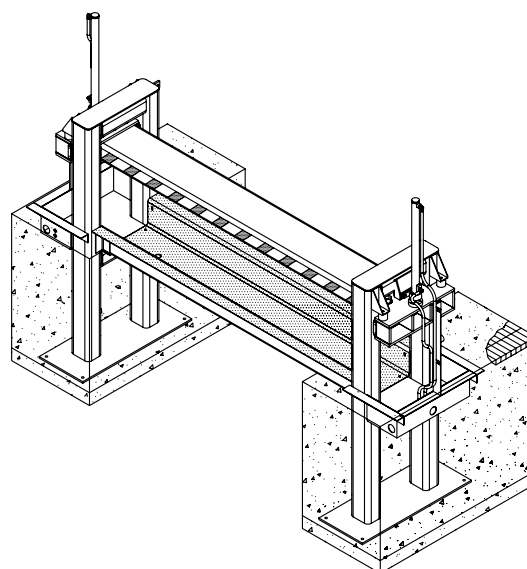

Boon Edam B.V.

P.O. Box 40, 1135 ZG Edam
The Netherlands

T +31 (0)299 38 08 08

E sales@boonedam.nl

F +31 (0)299 37 28 59

I www.boonedam.com



Security Access